

# **SIGNAMAX** **CONNECTIVITY SYSTEMS**

**Signamax™ Connectivity Systems**  
**10BaseT to 10BaseFL Converter**  
**Model 065-1140 Multimode**  
**Model 065-1150 Singlemode**

**U S E R ' S   G U I D E**

**Signamax<sup>TM</sup> Connectivity Systems**

**10BaseT to 10BaseFL Converter**

**Model 065-1140 Multimode**

**Model 065-1150 Singlemode**

**User's Guide**

## **FCC Warning**

This equipment has been tested and found to comply with the limits for a class A digital device, pursuant to Part 15 of the FCC Rules. These limits are designed to provide reasonable protection against harmful interference when the equipment is operated in a commercial environment. This equipment generates, uses and can radiate radio frequency energy and, if not installed and used in accordance with this user's guide, may cause harmful interference to radio communications. Operation of this equipment in a residential area is likely to cause harmful interference in which case the user will be required to correct the interference at his own expense.

## **CE Mark Warning**

This is a Class A product. In a domestic environment, this product may cause radio interference in which case the user may be required to take adequate measures.

## **Trademarks**

Product names mentioned in this manual may be trademarks or registered trademarks of those products and are hereby acknowledged.

- Ethernet is a trademark of Xerox Corporation.
- Microsoft Windows is a trademark of Microsoft Corporation.
- Signamax™ Connectivity Systems is a trademark of Advanced Electronic Support Products, Inc.

---

# TABLE OF CONTENTS

<b>CHAPTER 1:INTRODUCTION.....</b>	<b>1</b>
<b>PRODUCT OVERVIEW.....</b>	<b>1</b>
<b>FEATURES.....</b>	<b>3</b>
<b>SPECIFICATION.....</b>	<b>4</b>
<b>PACKAGE CONTENTS.....</b>	<b>5</b>
<b>CHAPTER 2: INSTALLATION.....</b>	<b>6</b>
<b>MDI/MDIX CONNECTION.....</b>	<b>6</b>
<b>POSITIONING OF CONVERTER.....</b>	<b>7</b>
<b>INSTALL YOUR CONVERTER.....</b>	<b>10</b>
<b>CONNECT TO A 10/100 DEVICE.....</b>	<b>10</b>
<b>CHAPTER 3: LED INDICATORS.....</b>	<b>11</b>
<b>LED INDICATORS.....</b>	<b>11</b>
<b>CHAPTER 4: MOUNTING.....</b>	<b>12</b>
<b>MOUNTING.....</b>	<b>12</b>
<b>CHAPTER 5: CABLES.....</b>	<b>14</b>
<b>CABLES.....</b>	<b>14</b>

---

# INTRODUCTION

---

## Product Overview:

---

The 10BaseT to 10BaseFL Converter is primarily designed for network or data installations that require the migration of cable media between conventional coppers based wiring to Fiber based installations.

These Converters have been specifically designed to support both a RJ-45 jack and a ST or SC fiber optic connector. This allows it to connect 10BaseT network to the 10BaseFL (fiber) networks.

In addition, this Converter features an MDI/MDI-X crossover “push button” switch for direct connection to either a workstation, switch or hub. This allows the network manager the freedom to configure between crossover and straight through when establishing connection between RJ-45 ports.

This converter can create potential distances of up to 12km (39600feet) with single mode fiber between a LAN switch and another switch or a file server.



Outlook for model 065-1140 10BaseT to 10BaseFL  
Converter with ST multimode connector



Outlook for model 065-1150 10BaseT to 10BaseFL  
Converter with SC singlemode connector

---

## **Features**

---

- Complies with 802.3 10BaseT/FL standard
- MDI/MDIX push button selection for RJ-45 port connection
- Supports ST multimode (model 065-1140) or SC singlemode (model 065-1150) fiber connector
- Extend fiber distance up to 12 km with singlemode fiber
- Compatible with other 10BaseT/FL and 10/100BaseT/TX devices
- Status LEDs for activity & link to easily monitor network activity
- External power supply

---

## Specifications

---

<b>Standard:</b>	IEEE 802.3u
<b>Connector:</b>	1 RJ-45, 1 ST for multimode or SC for singlemode
<b>Max. Distance:</b>	Twisted Pair: 100 m (330 ft) Multimode fiber: 2 km (6,600 feet) Singlemode fiber: 12 km (39,600 feet)
<b>Unit LEDs:</b>	<u>Power</u> - illuminated for normal operation
<b>Port LEDs:</b>	<u>Link</u> - illuminated when receiving link pulses from a compliant device <u>Receive</u> - flashing or illuminated when data packets are being received.
<b>Power:</b>	External power supply, 12VDC at 0.8A
<b>Temperature:</b>	<u>Operating</u> - 0 to 70° C (32 to 158° F) <u>Storage</u> - -20 to 70° C (-4 to 158° F)
<b>Humidity:</b>	<u>Operating</u> - 10% to 90%RH <u>Storage</u> - 5% to 90%RH
<b>Emissions:</b>	FCC Part 15 of Class A & CE Approved
<b>Dimensions:</b>	109.2 x 73.8 x 23.4 mm (LxWxH)
<b>Switch:</b>	Push button switch for twisted pair MDI/MDIX Connection

---

## **Package Contents**

---

- One Converter
- One AC adapter
- Four Self-Adhesive feet
- This Operation Manual

---

## INSTALLATION

To successfully install your converter, please refer to the following procedures:

- MDI/MDI-X Connection
- Positioning of Converter
- Install Your Converter

---

### MDI/MDI-X Connection

---

The MDI/MDI-X function alleviates the worry of type of cable to use to connect the converter with a 10BaseT device. Simply follow these instructions below when connecting the converter:

Device	Cable Configuration	Selection
Hub or switch	Straight Through	Select MDI-X
Hub or switch	Crossover	Select MDI
DTE (NIC)	Straight Through	Select MDI
DTE (NIC)	Crossover	Select MDI-X

## Crossover Selection Table

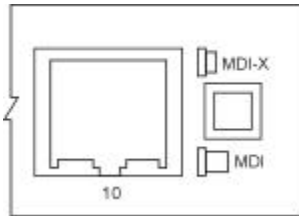

Location of Crossover Switch

---

## Positioning of Converter

---

In order to achieve the aim of effectively expanding an Ethernet network, one solution is to position two converters back to back between the following end devices:

### Example 1

- Two LAN Switch workgroups

Switch --- Converter --- Converter --- Switch

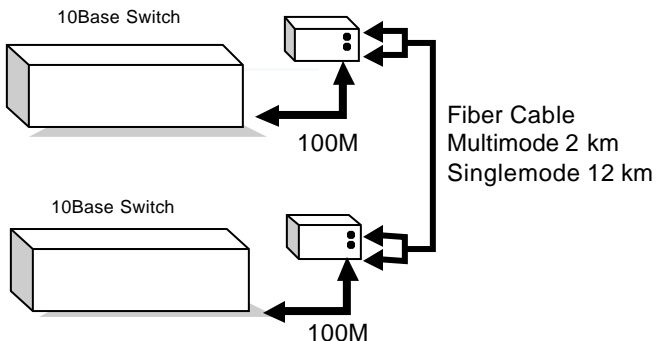

## Example 2

- A LAN Switch and a network's server

Switch --- Converter --- Converter --- Server

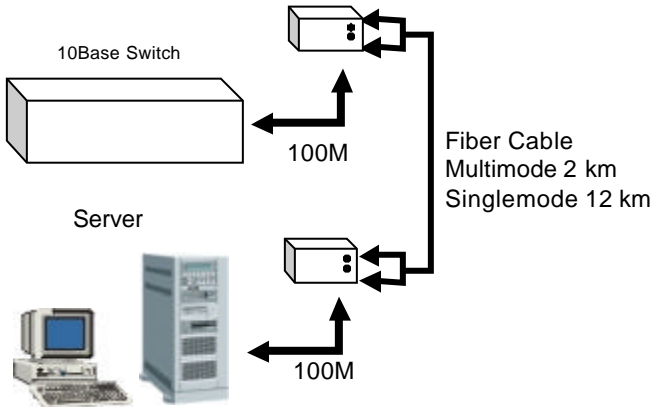

## Example 3

- A 10BaseT Hub and a Workstation

Hub --- Converter --- Converter --- Station

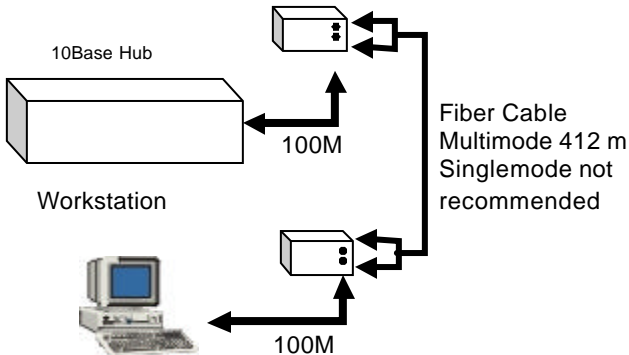

## Example 4

- A 10BaseT Network and a FL device

FL --- Converter --- Switch --- Hub --- WS

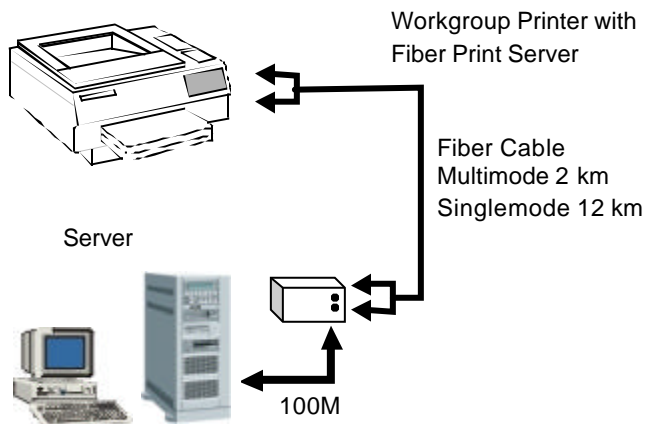

**Note:** The application that creates the most effective solution is to have a converter connected to operate directly between a fiber optic backbone and a departmental workgroup.

---

## **Install Your Converter**

---

### **Converter to 10BaseT Device Connection**

1. Make sure that the length for the straight through twisted pair cable (Category 3 or better) between the 10BaseT device (hub or switch) and the converter is no longer than 100 meters.
2. Connect one end of the twisted pair cable to the RJ-45 jack on the converter and the other end of the cable to the RJ-45 jack on the 10BaseT device.

### **Converter to Converter or 10BaseFL Device Connection**

1. Connect one (ST or SC) end of a fiber cable to either ST or SC connector on the converter. The other end of the cable will connect to the ST or SC connector on the other converter or the 10BaseFL device. The transmit (Tx) connector on one 10BaseFL device must connect to the receive (Rx) connector of the device it faces, and vice-versa.

### **Converter to a 10/100 Device**

When connecting this 10BaseT to 10BaseFL converter to a 10/100BaseT/TX device, the 10/100BaseT/TX device will be running at 10Mbps under half duplex mode only.

---

## LED INDICATORS

This converter has several LED to enable you to determine the status of the converter and to also see what is happening across your network. Their functions are as follows.

### **PWR**

**Power** – Illuminated during normal operation.

### **LNK**

**Link** – Illuminated when receiving link pulses from compliant devices

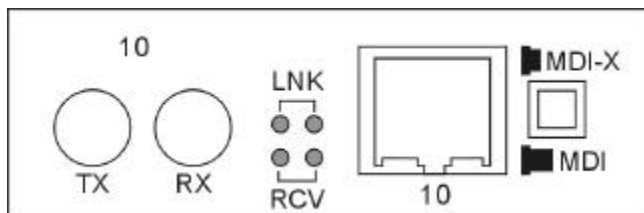

### **RCV**

**Receive** – Flashing or illuminated when data packets are being received

---

## **MOUNTING**

This converter can be placed in any location that will make its installation convenient. If you place the converter on a work surface or on top of existing networking equipment you may add the four rubber feet included in the packaging.

This converter can also be mounted on a vertical surface. Just use the template opposite and mark the position of the holes. Simply use two screws and mount the converter in place.

Please exercise caution when using power tools. Also take care to install this unit away from damp or wet locations, or in close proximity to very hot surfaces. This will have a detrimental effect on the converter and cables. An ideal location is in a lightly cooled environment, such as a typical equipment room.

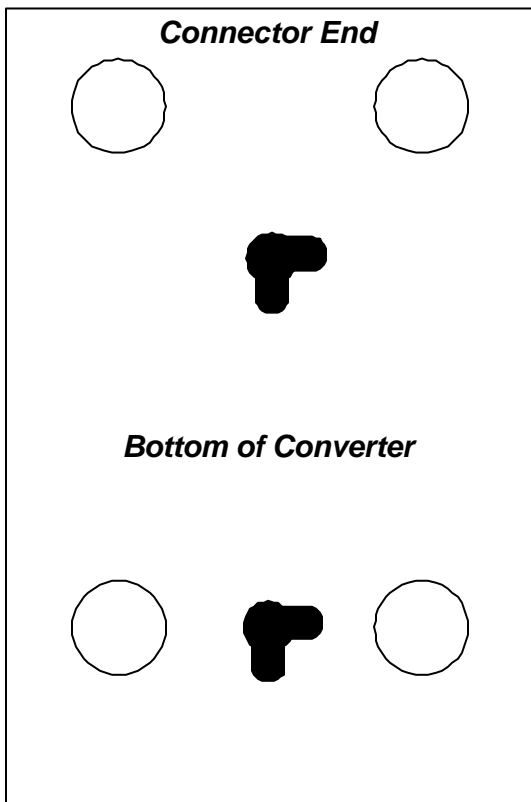

## CABLES

The following are some recommendations as to what you should and should not do when installing cables. Remember - cables are the deciding factor in deciding if a network performs to the maximum throughput.

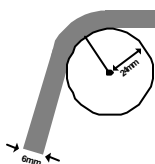

Try to maintain a bend radius of (min.) 4x the diameter of the cable for UTP and 100x for fiber.



Try not to allow the cable to twist too much - this creates a strain on the internal cables.

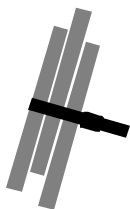

Place cable ties at regular intervals - do not over tighten cable ties - try to avoid using with fiber.

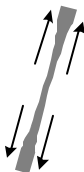

Do not stretch the cable especially on corners, in vertical cable trays and when spanning long distances.

---

## CONTACT INFORMATION

---

### **SIGNAMAX $\hat{O}$ CONNECTIVITY SYSTEMS**

#### **An AESP Company**

1810 N.E. 144th Street.

North Miami, Florida 33181, U.S.A.

Phone: 305-944-7710 Fax: 305-652-8489

Sales: 800-446-2377 Tech. Support: 800-446-2377, ext. 201

[Http://www.signamax.com](http://www.signamax.com)

E-mail: [info@signamax.com](mailto:info@signamax.com)

### **EUROPE**

#### **AESP Ukraine. (UKRAINE)**

2 Timiryazevskaya St. 47

252014 Kiev, Ukraine

Phone: +380 44 296.53.57

Fax: +380 44 294.88.60

[Http://www.aesp.com.ua](http://www.aesp.com.ua)

E-mail: [alesp@alesp.com.ua](mailto:alesp@alesp.com.ua)

#### **AESP Sweden. (SWEDEN)**

Grevegatan 19-21 SE-815

40 TIERP. SWEDEN

Phone:+46-(0)-293-228 88

Fax:+46-(0)-293-228 89

Phone:+49-81-35-9303-0

[Http://www.aesp.se](http://www.aesp.se)

E-mail: [info@alesp.se](mailto:info@alesp.se)

#### **JOTEC AESP AS. (NORWAY)**

Telefon 23 14 17 00 Ordrefax 23

14 17 10 Karihaugveien 102

Postboks 50 Ellingsrudasen 1006

Oslo, Norway

Phone:+47-23-14-1700

Fax:+47-23-14-1710

[Http://www.jotec.no](http://www.jotec.no)

E-mail: [jotec@jotec.no](mailto:jotec@jotec.no)

#### **AESP Russia. (RUSSIA)**

Kronshtadtsky Blv.

125499 Moscow, Russia

Phone:+7 095-456-0704

Phone:+7 095-456-0344

Fax:+7 095-454-3040

[Http://www.aesp.ru](http://www.aesp.ru)

E-mail: [alesp@alesp.ru](mailto:alesp@alesp.ru)

#### **AESP Germany GmbH (GERMANY)**

Weisserfelderstr.2 D-85551

Kirchheim b. München, Germany

Phone:+49-89-901-097-0

Fax:+49-89-901-097-22

E-mail: [alesp.info@t-online.de](mailto:alesp.info@t-online.de)

#### **INTELEK spol.s.r.o (CZECH REPUBLIC)**

Vlarska 22,

Brno, CZ 62700

CZE Czech Republic

Phone: +420-5-481-27248

Fax: +420-5-481-27247

[Http://www.intelek.cz](http://www.intelek.cz)

E-mail : [info@intelek.cz](mailto:info@intelek.cz)